

# HRV / ERV INSTALLATION AND OPERATING INSTRUCTIONS



## **HSHO-700**

Polypropylene Core

## **ESHO-700**

Enthalpy Core

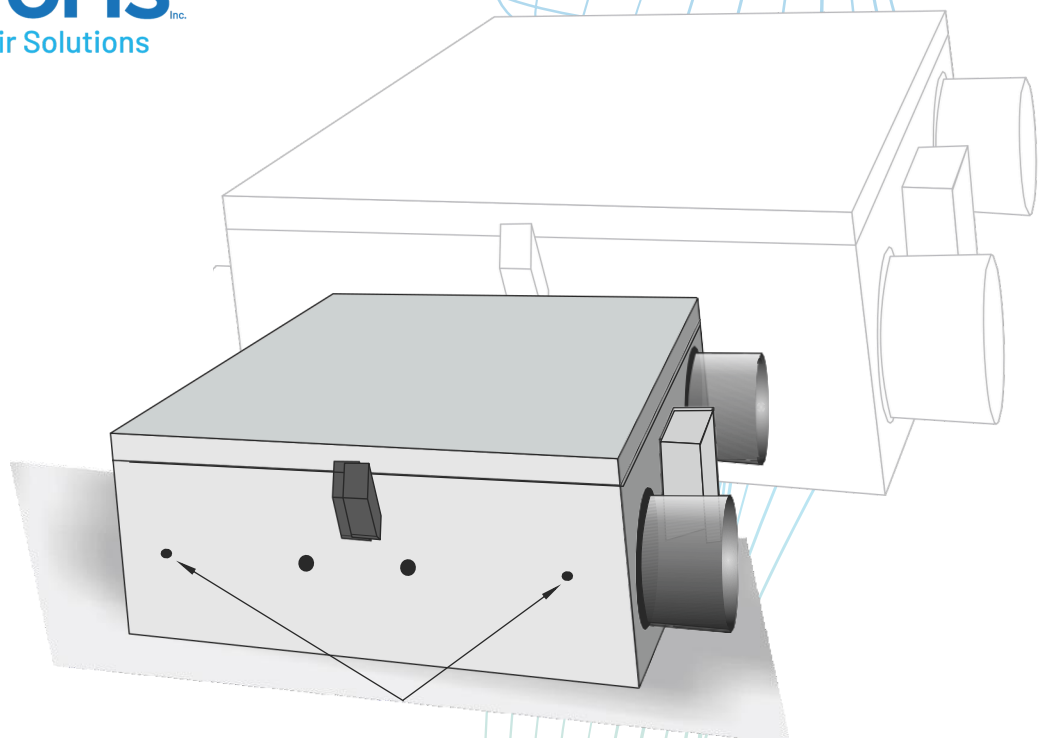

Field Balancing Ports



888.863.1562 | [info@auroris.org](mailto:info@auroris.org) | [www.auroris.org](http://www.auroris.org)

# IMPORTANT SAFETY INSTRUCTIONS

## READ AND SAVE THESE INSTRUCTIONS

### ⚠ WARNING ⚠

#### TO REDUCE THE RISK OF FIRE, ELECTRIC SHOCK OR INJURY, OBSERVE THE FOLLOWING:

1. Read all the instruction scare fully before installation, operation or maintenance of the unit. Failure to comply with instructions could result in personal injury and/or property damage.
2. Installation of the unit and the corresponding electrical wiring must be done by a qualified person and be in accordance with all municipal and national electrical codes and pertinent industry standards should be verified before installation.
3. Use this unit only in the manner in tended by the manufacturer.
4. "To ensure quiet operation of the ENERGYSTAR certified H/ERV, each product model must be installed using sound attenuation techniques appropriate for the installation."
5. "The way your heat/energy-recovery ventilator is installed can make a significant difference to the electrical energy you use. To minimize the electricity use of the heat/energy-recovery ventilator, a stand-alone fully ducted installation is recommended. If you choose a simplified installation that operates your furnace air handler for room-to room ventilation, an electrically efficient furnace that has an electronically commutated
6. (EC) variable speed blower motor will minimize your electrical energy consumption and operating cost."
7. "Installation of a user-accessible control with your product model will improve comfort and may significantly reduce the product model's energy use."
8. Moving Parts, Disconnect Power supply before opening. ensure that all the nuts and screws are securely fastened before restarting the unit.
9. Before servicing or cleaning the unit, switch power off at service panel and lock the service disconnecting means to prevent power from being switched on accidentally. When the service disconnecting means cannot be locked, securely fasten a prominent warning device, such as a tag, to the service panel.
10. To reduce the risk of fire, use only metal duct work.
11. For residential use only. The unit must be grounded.
12. Do not install in a cooking area.
13. This unit is not designed to exhaust combustion and/or dilution air for fuel burning appliances.

### ⚠ CAUTION ⚠

1. Turn the unit OFF during construction or repair to avoid filter blockage.
2. Exhaust air outside - Do not intake / exhaust air in spaces within walls, crawl spaces, garage, or into attics.
3. When leaving house for a long period of time (more th two weeks), a responsible person should check if unit operates adequately.

### PACKAGING INSPECTION

Open the box and check to make sure all the parts and accessories are present and in good condition. If you find any parts missing or any shipping damage please contact factory or our distributor immediately.

### CONTENTS

#### Parts List

- ESHO-S700 & HSHO-700 ..... 1

#### Wiring Diagram

- Control Board and Switches ..... 2
- Furnace / Fan-Coil / Heat Pump Interlock ..... 3

Standard Furnace Interlock Wiring

Alternate Furnace Interlock Wiring

#### HRV and ERV Typical Installations

- Horizontal Vertical installation ..... 4
- Single Vent & Access Door installation ..... 5
- Drain connection ..... 5

#### Air Flow Balancing

- Balancing Procedure ..... 6
- Pitot tube Air Flow balancing ..... 6

#### Maintenance

- Regular Maintenance ..... 7
- Annual Maintenance ..... 8

Troubleshooting ..... 9

Climate Zone ..... 9

**Maxum Series**

model:

**ESHO-700**

**HSHO-700**

Polypropylene Core

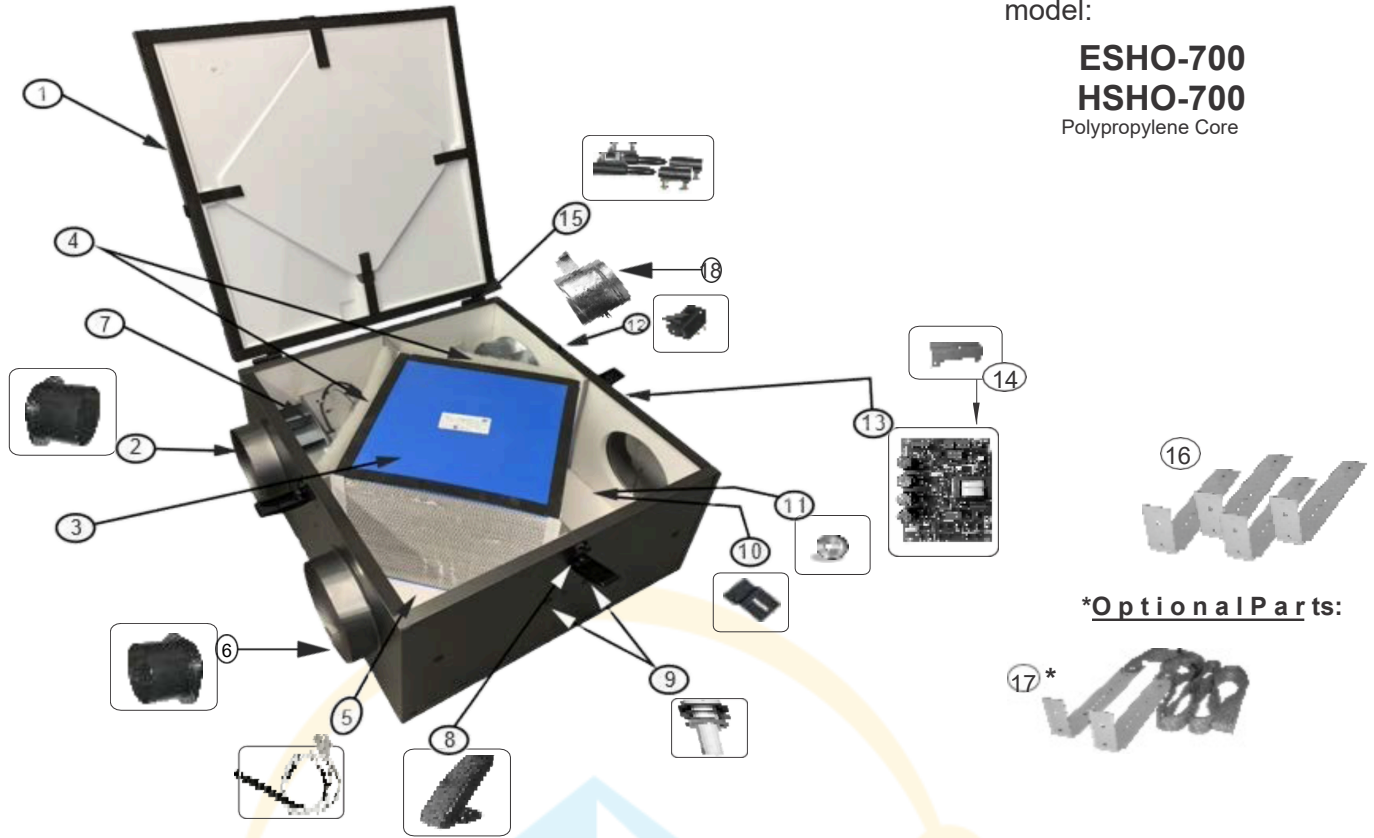

**\*Optional Parts:**

Reference	Description	Part No.	ESHO-700	HSHO-700
			QTY	QTY
1	HRV/ERV - Lid, Pan Assembly	9315	1	1
2	Steel Collar - 10" Diameter	SC10	4	4
3	Polypropylene Core	RHRV-S700PCORE	N/A	1
	Enthalpy Core	RERV-S700CORE	1	N/A
4	Filter 22.75" x 13.5"	RERV-S700F	2	2
5	Temperature Sensor	9326	1	1
6*	Backdraft Damper - 10" Diameter	RD10	2	2
7	RI-700 Blower - RHRV/ERV-S700	13032	2	2
8	Adjustable Door Latch	9319	3	3
9	Drain Spout Assembly	9320	2	2
10	Core locking Bracket	9321	1	1
11	Core locking Nut	14016	1	1
12	Safety Switch	9322	1	1
13	Main Control Board RHRV/ERV-S700	9356(8A)	1	1
14	Main Control Board Bracket	9355	1	1
15	Door Hinges	9328	1 set	1 set
16	Mounting Brackets	11135	4	4
17*	Webbing/Brackets/Ladder Locks	9332	2 sets	2 sets
18*	120V Motorized Spring Return Damper - 10"	9399	1	1

Recently we modified our control board layout to provide easy wiring connections for timer switches/ Intermittent switch (low voltage) without accessing to our electrical box. Initially, some units may come with older version or newer version of Control Boards. But overall functionality of both type of boards are same.

## CONTROL BOARD: New Version

Optional Accessories (Not Supplied)

- a) Timer Switch (TC100-5V)
- b) Wall Switch
- c) Dehumidistat
- d) Time Delay Switch (TC100-120 & TC100-120P)
- e) Master On/Off Switch for HRV/ERV
- f) Light
- g) Intermittent Switch (IC 100-5V)

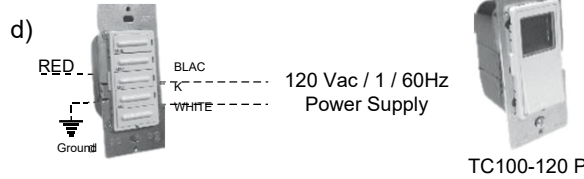

TC100-120 P

**Note:** Same power source can be used for wall switch, Time delay switch (TC100-120 & TC100-120P) and HRV/ERV

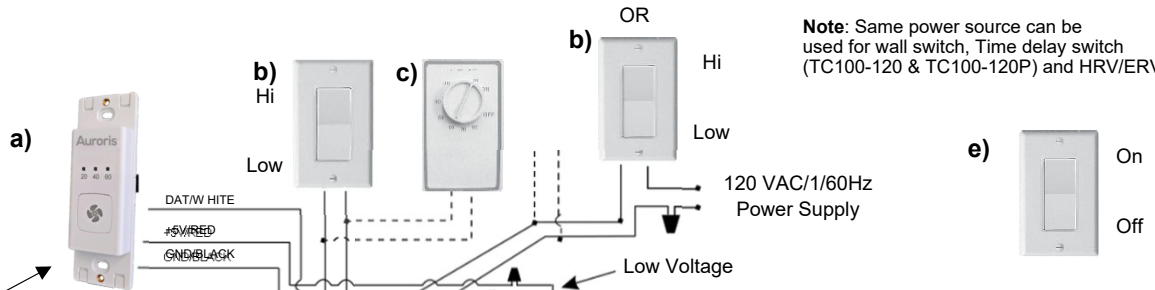

**Note:**

Up to 4 Timer Switches (TC 100-5V) and one intermittent switch (IC 100-5V) can be connected to control board of HRV/ERV by using three 24 AWG (min.) Copper wires as shown. Maximum total wire length 75ft. (see option 2)



(Also available without OFF mode upon request)

4 - Speed Controller (Fan Balancing and (Turn the Knob clockwise to increase speed)

to Control Board

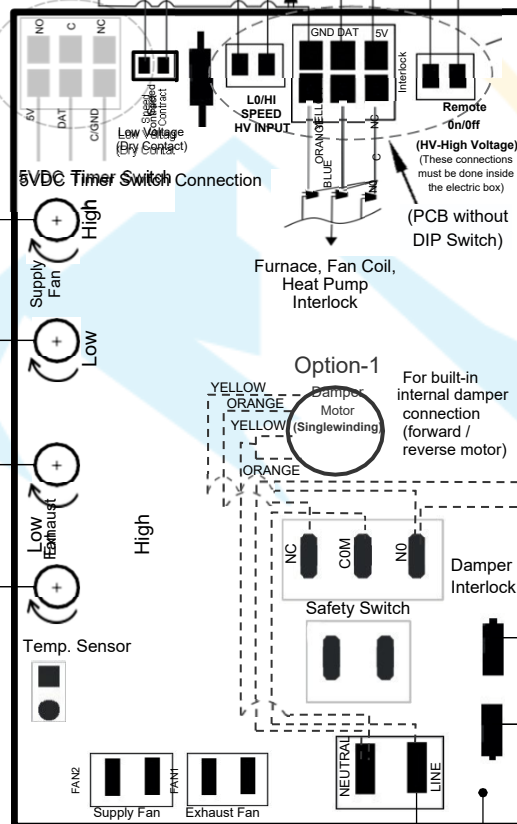
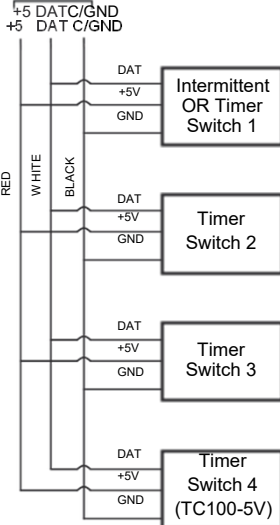

**Light / Switch Option**

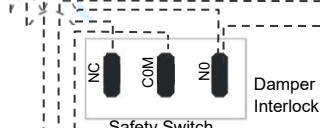
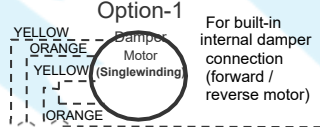
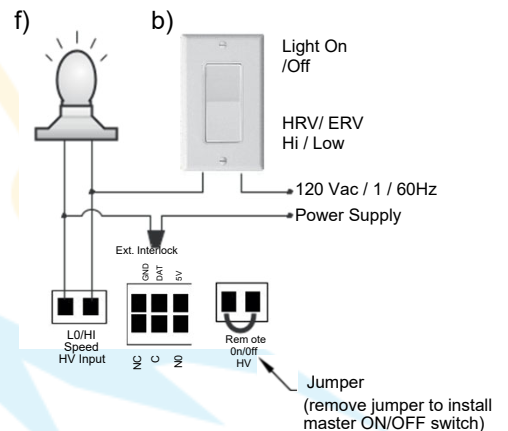

**Note:**

Make sure, the Line must be connected to Line and Neutral connected to Neutral. Unit will not function if not connected correctly.

**FAN#1** - Single Speed (Bathroom Exhaust fan connection for "Project Series")

Model # RHRV-P100A  
RHRV-P100P  
RERV-P100

## Furnace / Fan-Coil / Heat Pump Interlock:



Never connect a 120volt AC circuit to the terminals of the furnace/fan-coil/heat pump interlock(Standard Wiring). Only use the low voltage class 2 circuit.

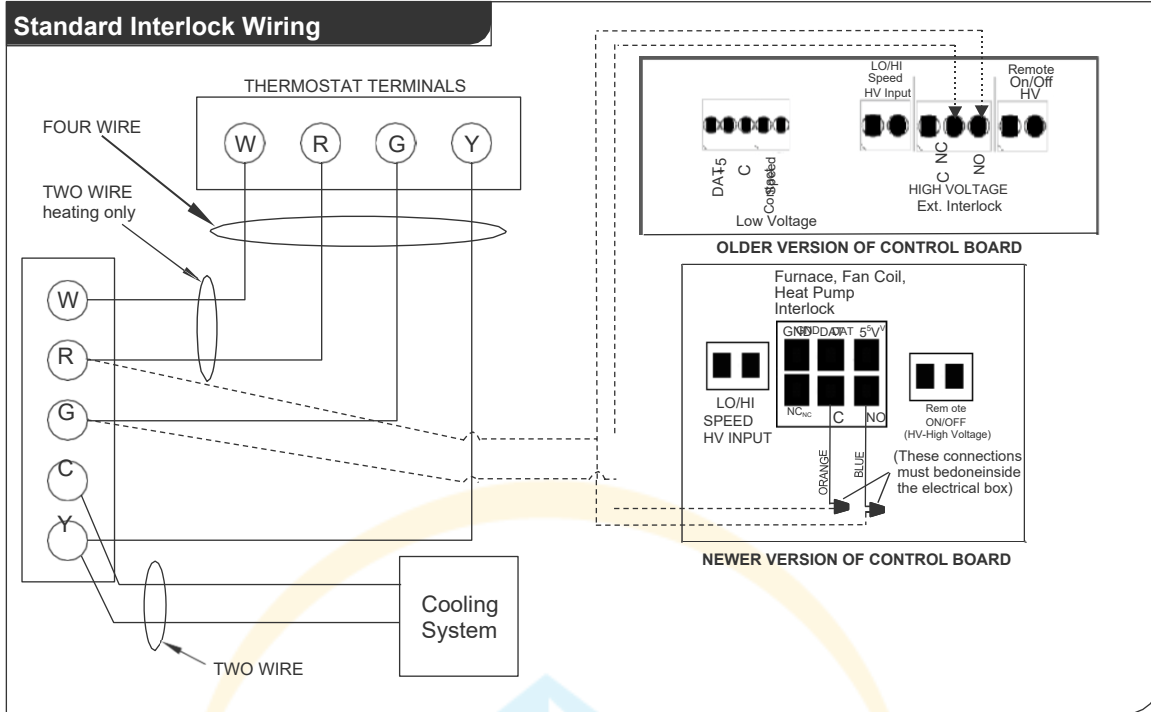

## For a furnace connected to a cooling system:

On some older thermostats, energizing the R and G terminals at the furnace has the effect of energizing Y at the thermostat and there by turning on the cooling system. If you identify this type of thermostat, you must use the "Alternate Interlock Wiring".

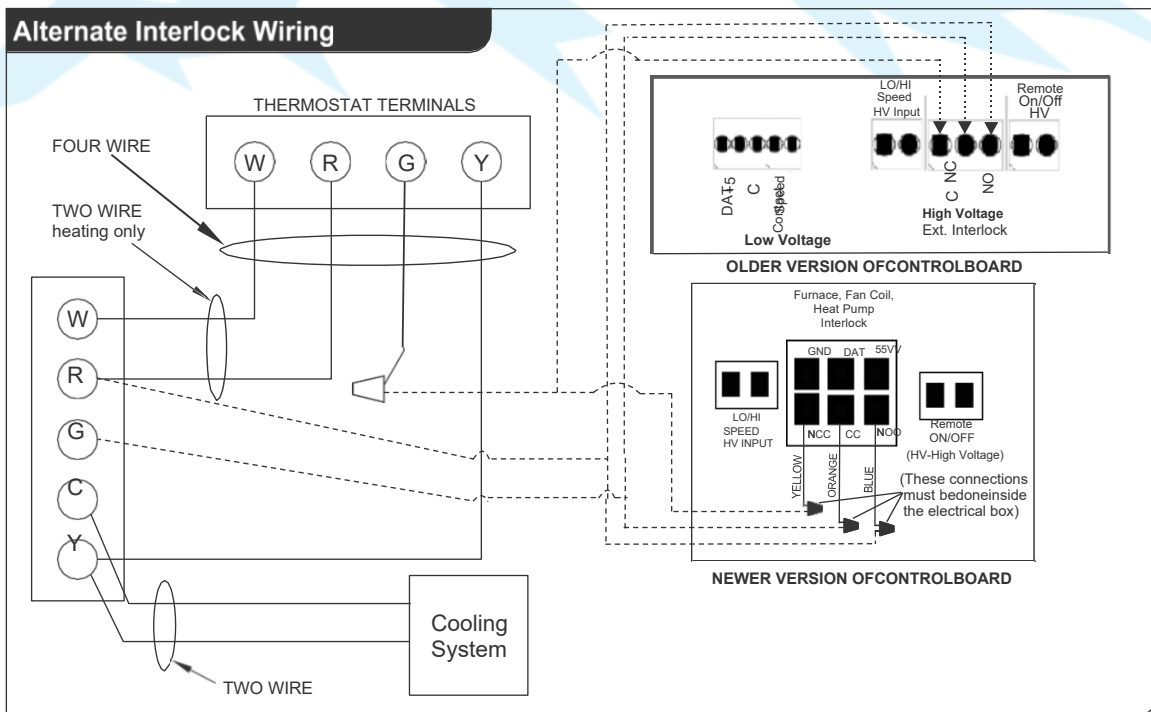

## HRV and ERV Typical Installations

### HORIZONTAL

**Note:**

- 30" clearance (300CFM) and 34" clearance (500cfm) is recommended for cleaning of the core/servicing the unit.
- Dampers are installed for horizontal installation. For vertical installation both dampers have to be turned so they can open properly and close when there is any back draft.
- **Make sure no screw will interfere the function of the backdraft damper flaps while installing the duct work to the HRV/ERV.**

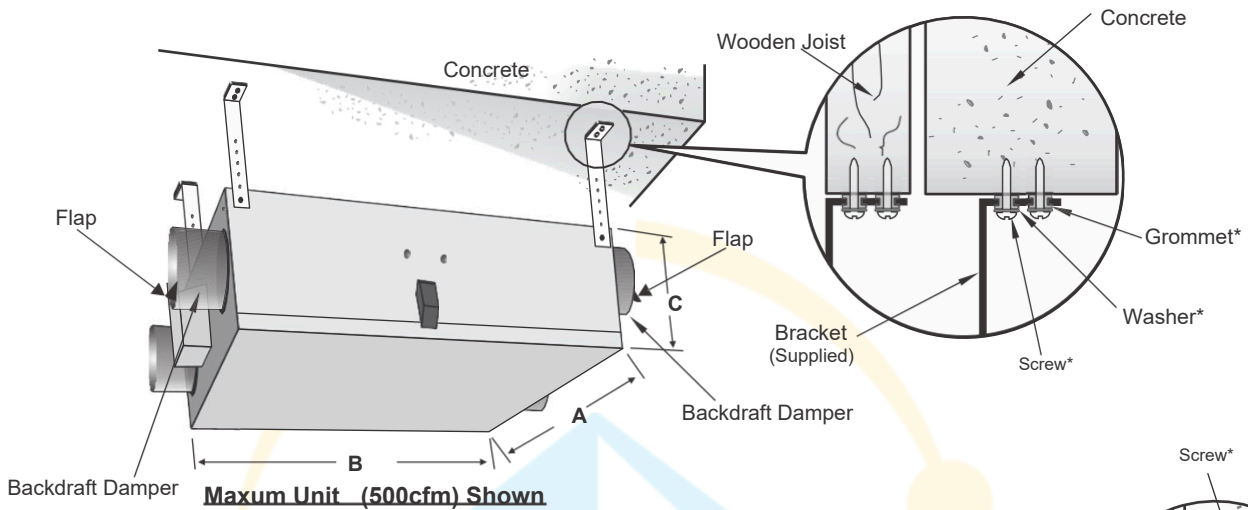

**Maxum Unit (500cfm) Shown**

	A	B	C
<b>S700, S700P</b>	36"	36"	16.125"

\*NOT SUPPLIED

### VERTICAL

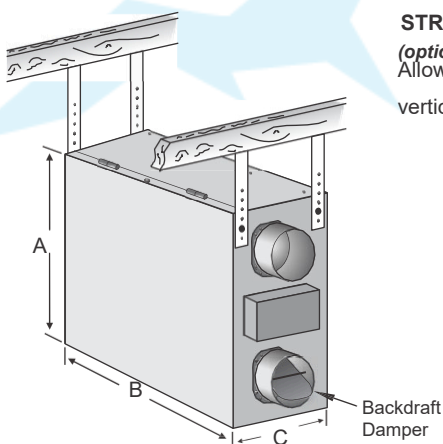

**Maxum Unit (500cfm) Shown**

**STRAPPING SYSTEM:**

*(optional)*  
Allows one person installation for vertical and horizontal installation.

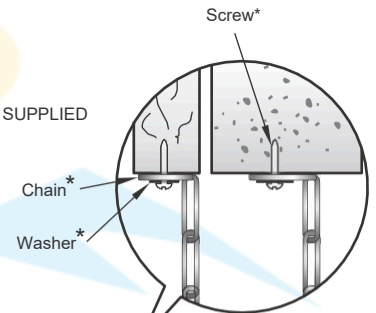
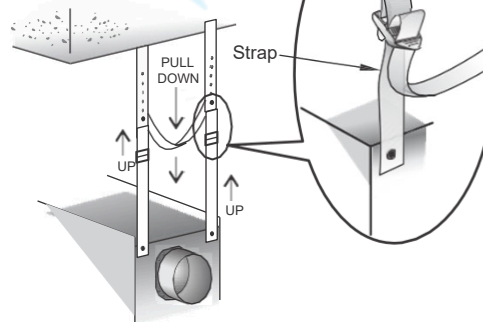

**CHAIN MOUNTING SYSTEM:**

*(optional)*  
Available for both horizontal & vertical installation.

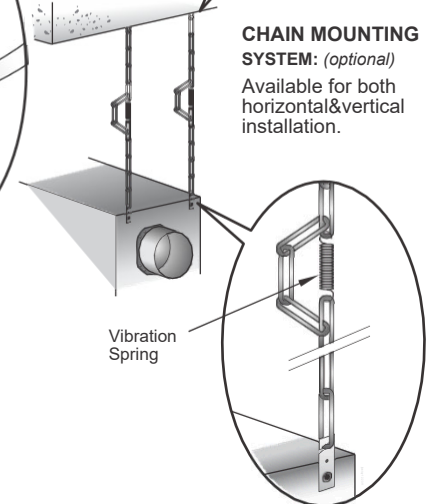

**Note:**

After installation make sure the HRV/ERV is properly leveled. If not level led correctly, then defrost will not perform effectively and/or unit may frost in winter.

## Typical Installations of Single Vents & Access door

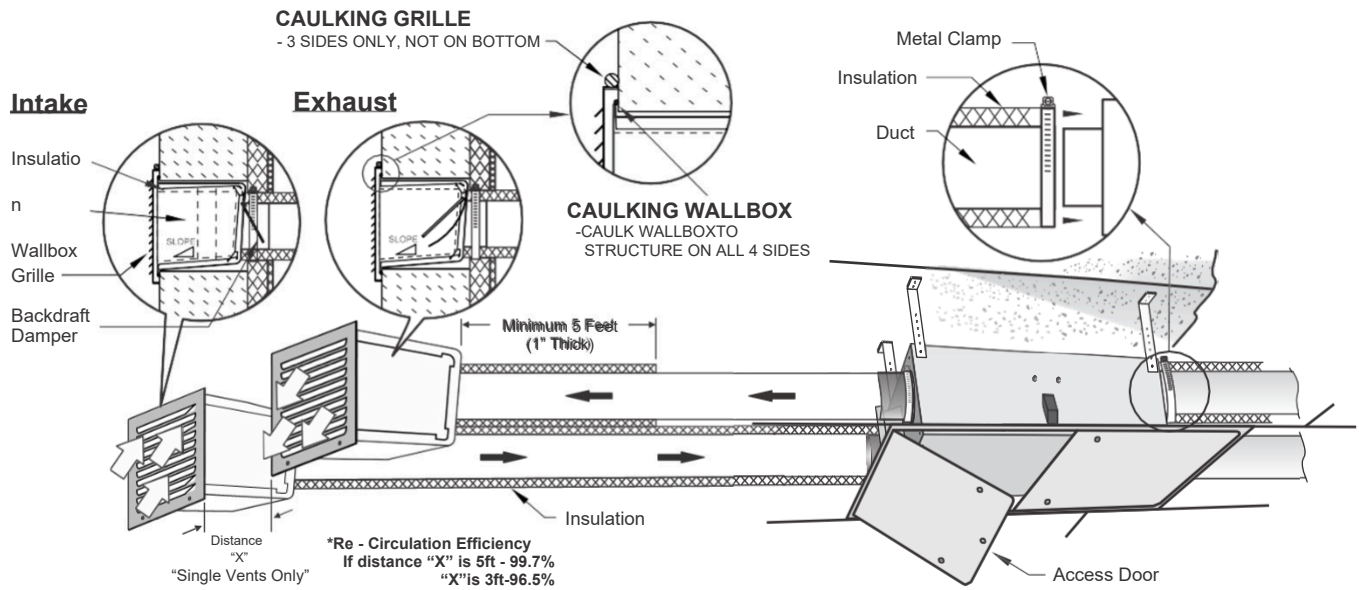

**Note:**

-Fresh air intake and supply duct must be totally insulated. Exhaust duct must be 5 feet insulated. In colder climate, it is recommended to insulate all exhaust and supply ducts.

-Use appropriate access door size for easy access and routine maintenance of the unit. For more info visit <https://auroris.org/>

## Drain Connection

When the outside temperature drops below  $-5^{\circ}\text{C}$ , the Reversomatic HRV / ERV Supply Fan cycles ON / OFF depend on the outside temperature. The exhaust fan always operates normally at all times regardless of the outside air temperature. During defrost cycle the HRV unit may produce some condensation and the water should flow into a nearby drain. The HRV cabinet has pre-punched holes for the drain, in order to keep the drain pan intact *hand tighten* the 2 plastic drain tube to the unit using the gasket and nuts.

### For Vertical installation

Cut two sections of  $\frac{1}{2}$ " drain pipe and connect the other ends to the drain tube then connect to " T " connector. Connect a drain line and create a **P-trap** to prevent the unit from unpleasant odours from drain source. Tape or fasten base to avoid any bends.

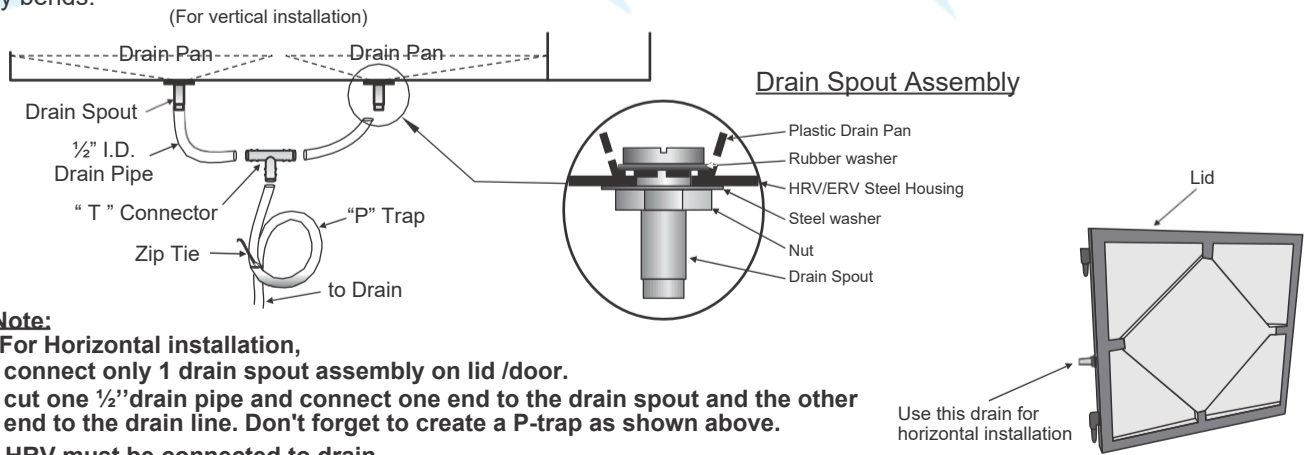

**Note:**

-For Horizontal installation, connect only 1 drain spout assembly on lid / door. cut one  $\frac{1}{2}$ " drain pipe and connect one end to the drain spout and the other end to the drain line. Don't forget to create a P-trap as shown above.

- HRV must be connected to drain.
- ERV does not required any drain. However, we recommend to connect ERV to drain in areas where extreme cold weather conditions are expected.

**CAUTION**

The HRV and all condensate lines must be installed in a space where the temperature is maintained above the freezing point or freeze protection must be provided.

## Air Flow Balancing

**Balancing Procedure**

It is required to have balanced airflows in an HRV/ERV. The volume of air brought in from the outside must equal the volume of air exhausted by the unit while running at normal speed. If the air flows are not properly balanced, then:

- The HRV/ERV may not function at its maximum efficiency
- A negative or positive air pressure may occur in the house or condo
- The unit may not defrost properly

**Prior to balancing, ensure that:**

1. All the HRV/ERV's components are in place and functioning properly.
2. All sealing of the duct work system has been completed.
3. Set the unit to normal speed.
4. Air flows in branch to specific areas of the house should be adjusted first prior to balancing the unit.
5. After taking reading of both the stale air to the HRV/ERV duct and fresh air to the house duct, the duct with the lower CFM reading should be left alone while the duct with the higher airflow should be slower down to
6. match the lower reading by adjusting dial/speed controller on control board (see board layout on page-4).  
Return unit to appropriate fan speed for normal operation.

**Pitot Tube Airflow Balancing**

The following is a method of field balancing an HRV/ERV using a Pitot tube advantageous in situations when flow stations are not installed in the ductwork. Procedure should be performed with the HRV/ERV on normal speed.

The first step is to operate all mechanical systems on most desired speed, which have an influence on the ventilation system, i.e. the forced air furnace or air handler if applicable. This will provide the maximum pressure that the HRV/ERV will need to overcome, and allow for a more accurate balancing of the unit.

Drill a small hole in the duct (about 3/16"), three feet downstream of any elbows or bends, and one foot upstream of any elbows or bends. These are recommended distances but the actual installation may limit the amount of straight duct.

The Pitot tube should be connected to a magnehelic gauge capable of reading from 0 to 0.25 in. (0-62 Pa) or other digital airflow meter. The tube coming out of the top of the pitot is connected to the high pressure side of the gauge/meter and the tube coming out of the side of the pitot is connected to the low pressure or reference side of the gauge/meter.

Insert the pitot tube into the duct; pointing the tip into the airflow. For general balancing it is sufficient to move the pitot tube around in the duct and take an average or typical reading. Repeat this procedure in the other duct. Determine which duct has the highest airflow (highest reading on the gauge). Then slow down that motor speed by adjusting dial/speed controller on control board to match the lower reading from the other duct. The flows should now be balanced. Actual airflow can be determined from the gauge/meter reading. The value read on the gauge is called the velocity pressure and on the flow meter is called air velocity (FPM). The Pitot tube comes with a chart that will give the air flow velocity based on the velocity pressure indicated by the gauge. This velocity will be in either feet per minute or metres per second. To determine the actual airflow, the velocity is multiplied by the cross sectional area of the duct being measured.

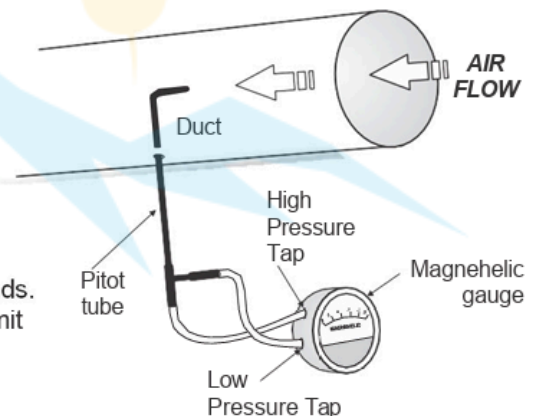
**Pitot tube and gauge****NOTE:**

Place the magnehelic gauge on a level surface and adjust it to zero.

**Note:(Option #2)- Only for “superior” series**

- \*For balancing, extension box cover plate is provided with 3 holes on supply side and 3 holes on exhaust side.
- \*Do not use pitot tube to open holes in the insulation as it may block/damage the pitot tube.
- \*Take 3 readings on each hole and average all 9 readings for supply and same for exhaust.
- \*After finish balancing, plug all six holes with plastic plugs provided with the unit.

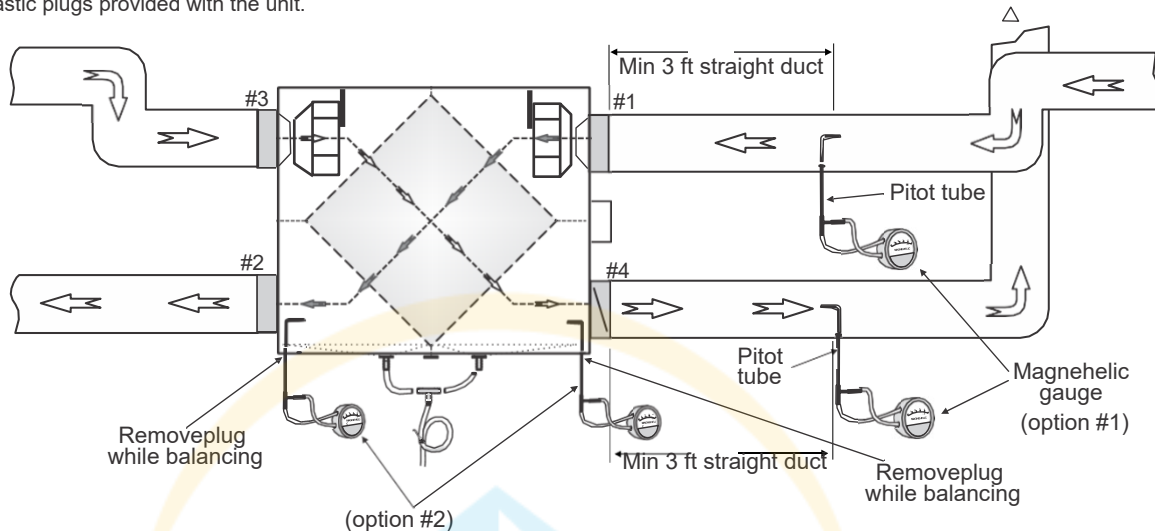

**Note:** To take more accurate readings, use option #1 (if possible).  
Project and Project Condo Units use Option #1

$$\text{CFM} = \text{Opening} / \text{Cross-sectional Area (sq. ft.)} \times \text{velocity (FPM)}$$

The accuracy of the flow reading will be affected by how close to any elbows or bends the readings are taken. Accuracy can be increased by taking an average of multiple readings as outlined in the literature with the Pitot tube.

## Maintenance

### Regular Maintenance

1. Turn the unit off and disconnect the power supply.
2. Unlatch the door and lift the door panel towards you, hold it firmly and slide it to the left.
3. Clean the inside of the *door* and *drain pan* with a damp cloth to remove dirt and debris that may be present.
4. Clean the *filters*: (twice a year)
  - Remove the filters.
  - Vacuum to remove most of the dust.
  - Wash with a mixture of warm water and mild soap. Rinse thoroughly and shake filters to remove water and let dry.
5. Oil defrost damper levers and hinges.
6. Check the exterior fresh air supply hood:
  - Make sure there are no leaves, twigs, grass, ice or snow that could be drawn into the vent.

**Partial blocking of this air vent could cause the unit to malfunction.**
7. Reassemble the components, Filters and Door (The door is secured when you hear a click.)
8. Reconnect the power and turn on the unit.

### Annual Maintenance

Repeat steps 1 to 5 from the previous section and continue with the following steps:

1. Clean the HRV and ERV core:

- Remove filters
- Loosen the core locking bracket
- Remove the core, carefully grip ends of core and pull evenly outward

- **HRV Core** > remove dust using vacuum cleaner or rinse with cold water
  - > Soak and rinse the HRV core in warm soapy water
- **ERV Core** > remove dust using vacuum cleaner

**⚠ ATTENTION ⚠**

- Do not use cleaning solution for the HRV/ERV core
- Do not use pressure washer on the HRV/ERV core
- Do not place the HRV/ERV core in dishwasher
- Do not use bleach or chlorine

1. **Motors** - Maintenance Free, permanently lubricated

3. **Drain Tube and Drain Pipe**- Inspect drain tube, drain pipe and “P” trap for blockage, mold or kinks. Flush with warm soapy water and replace if worn, bent or unable to clean.

4. **Clean Duct Work if Required** - Wipe and vacuum the duct once every year. The duct work running to and from HRV/ERV may accumulate dirt. You may wish to contact a heating / ventilation company to do this.

5. **Cleaning the Fans** - Fans may accumulate dirt causing an imbalance and/or excessive vibration on the HRV/ERV. A reduction in the airflow may also occur. In new construction this may result within the first year due to heavy dust and may occur periodically after that overtime depending on the outdoor conditions.
- unplug the HRV/ERV
  - open the service door
  - remove the core
  - disconnect the fan motor wires
  - remove the screws securing fan assembly
  - pull the fan assembly out of unit
  - check for any accumulation on the blades
  - clean with a small brush if necessary:
    - scrub individual fan blades until clean
    - vacuum and wipe
  - put the components back in place
  - reconnect the power supply and turn the unit back on.

Note: Warranty will be void if regular/annual Maintenance is not performed as recommended and instructed above.

**⚠ WARNING ⚠**

Electrical shock hazard. Can cause injury or death. Before attempting to perform any service or maintenance, always disconnect the unit from its power source.

### Trouble shooting

PROBLEMS	POSSIBLE CAUSES	SOLUTIONS
1. Air flow is low	<ul style="list-style-type: none"> <li>- HRV/ERV airflow improperly balanced</li> <li>- filter clogged</li> <li>- core obstructed</li> <li>- exterior fresh air supply blocked</li> <li>- damper is closed (if supplied)</li> <li>- ductwork is restricting</li> <li>- power supply low (Low Voltage)</li> </ul>	<ul style="list-style-type: none"> <li>- have professional balancer or contractor balance the unit</li> <li>- remove and clean filter</li> <li>- remove and clean core</li> <li>- remove and clean the blockage</li> <li>- check damper</li> <li>- inspect duct installation</li> <li>- switch off the unit immediately and call the electrician to check the voltage</li> </ul>
2. Senses cold air from Supply	<ul style="list-style-type: none"> <li>- Exhaust hood outside the building is blocked</li> <li>- HRV/ERV airflow improperly balanced</li> <li>- outdoor temperature is extremely cold</li> </ul>	<ul style="list-style-type: none"> <li>- remove the blockage and clean the hood</li> <li>- have contractor balance the unit - place ment of furniture or closed doors is restricting the movement of air in the home</li> <li>- install a duct heater</li> </ul>
3. Water in the bottom of HRV	<ul style="list-style-type: none"> <li>- drain pans, drain tube, drain pipe and “P” trap are clogged</li> </ul>	<ul style="list-style-type: none"> <li>- check for blockage and for kinks in line</li> <li>- check connections</li> <li>- make sure water drains properly</li> </ul>

4. Timer switch 20/40/60 minute light doesn't stay on	<ul style="list-style-type: none"> <li>- loose connection</li> <li>- the switch may be defective</li> <li>- turn off the HRV/ERV bracker</li> </ul>	<ul style="list-style-type: none"> <li>- check connection</li> <li>- replace the timer switch</li> <li>- reset the main controller</li> </ul>
5. Unit is not defrosting properly	<ul style="list-style-type: none"> <li>- fresh air duct maybe frozen</li> <li>- HRV/ERV airflow improperly balanced</li> <li>- Temp. sensor maybe defective</li> </ul>	<ul style="list-style-type: none"> <li>- check and remove the ice</li> <li>- have professional balancer or contractor balance the unit</li> <li>- replace the Temp. sensor</li> </ul>
6. All 3 LEDs of timer switch blinks	<ul style="list-style-type: none"> <li>- Control board reports error</li> <li>- lost communication with main control board</li> </ul>	<ul style="list-style-type: none"> <li>- refer to problem 4.</li> <li>-check all wire connections on timer switch and main control board</li> </ul>
7. LED's on the Main Control board and the remote wall mount Timer Switch will flash 0.5 second On then 2 seconds Off then repeat the cycle (1 Blink)	<ul style="list-style-type: none"> <li>- Exhaust fan open circuit:                             <ul style="list-style-type: none"> <li>a) motor burned</li> <li>b) fan overheated</li> </ul> </li> </ul>	<ul style="list-style-type: none"> <li>- replace motor</li> <li>- call technician (if possible replace fan)</li> </ul>
8. LED's on the Main Control board and the remote wall mount Timer Switch will flash 0.5 sec On/0.5 sec Off/0.5 sec On then 2 sec Off, then repeat the cycle (2 Blinks)	<ul style="list-style-type: none"> <li>- damper obstructed</li> <li>- exhaust fan jam / over-current</li> </ul>	<ul style="list-style-type: none"> <li>- check backdraft damper, no screw must interfere the function of the damper</li> <li>- replace the fan</li> </ul>
9. LED's on the Main Control board and the remote wall mount Timer Switch will flash 0.5 sec On/0.5 sec Off/0.5 sec On/0.5 sec Off/ 0.5 sec On, then 2 seconds Off, then repeat the cycle (3 Blinks)	<ul style="list-style-type: none"> <li>- Supply fan open circuit:                             <ul style="list-style-type: none"> <li>a) motor burned</li> <li>b) fan overheated</li> </ul> </li> </ul>	<ul style="list-style-type: none"> <li>- replace motor</li> <li>- call technician (if possible replace fan)</li> </ul>
10. LED's on the Main Control board and the remote wall mount Timer Switch will flash 0.5 sec On/0.5 sec Off/0.5 sec On/0.5 sec Off/ 0.5 sec On/0.5 sec Off/0.5 sec On then 2 seconds Off, then repeat the cycle (4 Blinks)	<ul style="list-style-type: none"> <li>- damper obstructed</li> <li>- Supply Fan jam / over-current</li> </ul>	<ul style="list-style-type: none"> <li>- check back-draft damper, no screw must interfere the function of the damper</li> <li>- replace the fan</li> </ul>
11. LED's on the Main Control board and the remote wall mount Timer Switch will flash: 0.5 sec On/0.5 sec Off/ 0.5 sec On/0.5 sec Off/ 0.5 sec On/0.5 sec Off/ 0.5 sec On/0.5 sec Off/ 0.5 sec On/0.5 sec Off/ 0.5 sec On, then 2 seconds Off, then repeat the cycle (5 Blinks)	<ul style="list-style-type: none"> <li>- temperature sensor failure (both motors shuts off)</li> </ul>	<ul style="list-style-type: none"> <li>- replace temperature sensor</li> </ul>

Note :- Lightning, high power surge or high frequency radio signals could cause HRV/ERV goes into safe mode (unit completely shuts off and timer switches blinks either two or four times in a raw every 2 seconds interval). If this happens, turn "off" the main power of the HRV/ERV and restart the unit. If still unit does not come on, please call service technician.

## Select HRV/ERV for your Climate Zone

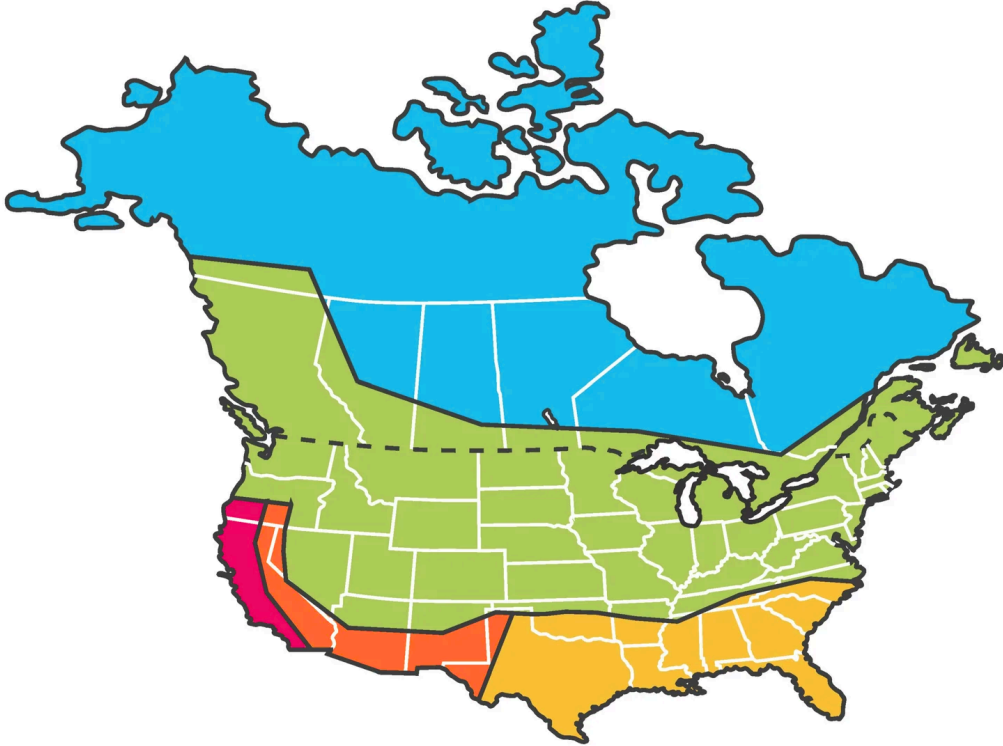

<b>HRV</b>		<b>HRV, ERV</b> (optional)	
	Severe Conditions		Pacific Conditions
	Moderate Conditions	<b>ERV</b>	
	Dry Climate		High Humidity

*U.S. Department of Energy climate zones map*

*HRVs are recommended for colder climates.*

*ERVs are designed for warm-humid climates with long cooling seasons.*



888.863.1562 | [info@auroris.org](mailto:info@auroris.org) | [www.auroris.org](http://www.auroris.org)