

# HRV / ERV INSTALLATION AND OPERATING INSTRUCTIONS

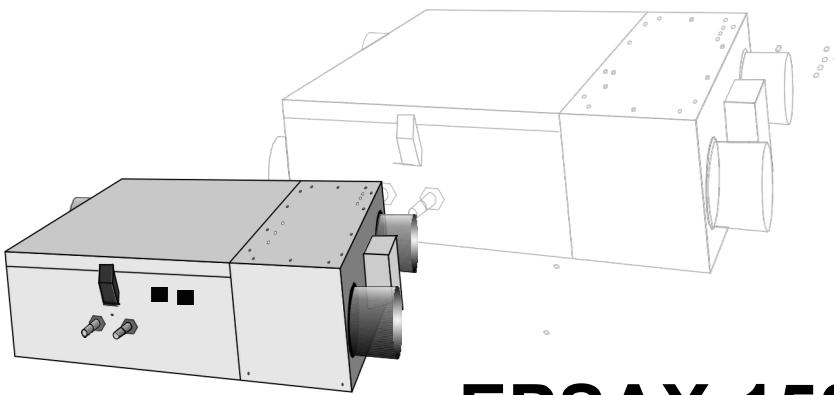

## EPSAX-150

Enthalpy Core

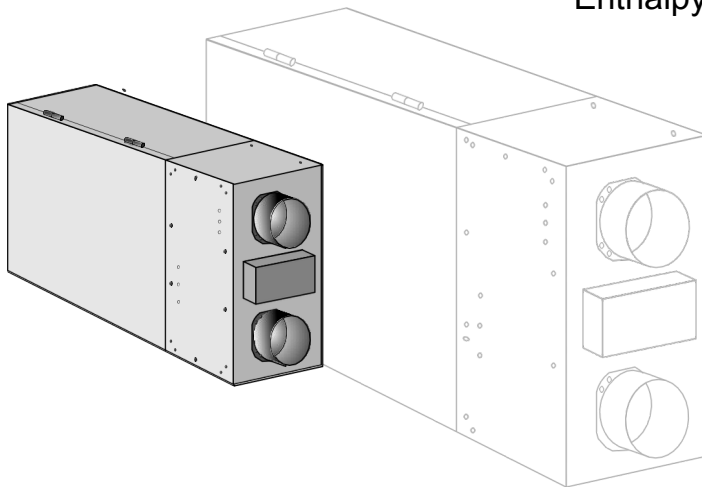

888.863.1562 | [info@auroris.org](mailto:info@auroris.org) | [www.auroris.org](http://www.auroris.org)

# IMPORTANT SAFETY INSTRUCTIONS READ AND SAVE THESE INSTRUCTIONS

## ⚠ WARNING ⚠

**TO REDUCE THE RISK OF FIRE, ELECTRIC SHOCK OR INJURY, OBSERVE THE FOLLOWING:**

1. Read all the instructions carefully before installation, operation or maintenance of the unit. Failure to comply with instructions could result in personal injury and/or property damage.
2. Installation of the unit and the corresponding electrical wiring must be done by a qualified person and be in accordance with all municipal and national electrical codes and pertinent industry standards should be verified before installation.
3. Use this unit only in the manner intended by the manufacturer. If you have any questions, contact the manufacturer.
4. Moving Parts, Disconnect Power supply before opening. ensure that all the nuts and screws are securely fastened before restarting the unit.
5. Before servicing or cleaning the unit, switch power off at service panel and lock the service disconnecting means to prevent power from being switched on accidentally. When the service disconnecting means cannot be locked, securely fasten a prominent warning device, such as a tag, to the service panel.
6. When cutting or drilling into wall or ceiling, make sure that you do not damage electrical wiring and other hidden utilities.
7. To reduce the risk of fire, use only metal ductwork. Do not use any accessories not recommended by the manufacturer.
8. When performing installation, servicing or cleaning these unit, it is suggested to wear safety glasses and gloves.
9. Do not use this unit for commercial purpose.
10. For residential use only. The unit must be grounded.
11. Do not install in a cooking area.
12. This unit is not designed to exhaust combustion and/or dilution air for fuel burning appliances.

## ⚠ CAUTION ⚠

1. Turn the unit OFF during construction or repair to avoid filter blockage.
2. Exhaust air outside - Do not intake / exhaust air into spaces within walls, crawl spaces, garage, or into attics.
3. Unit has to be installed in accordance to National and Local Building Code.
4. When leaving house for a long period of time (more than two weeks), a responsible person should check if unit operates adequately.
5. Published efficiencies are based on balanced air-flows on supply and exhaust.

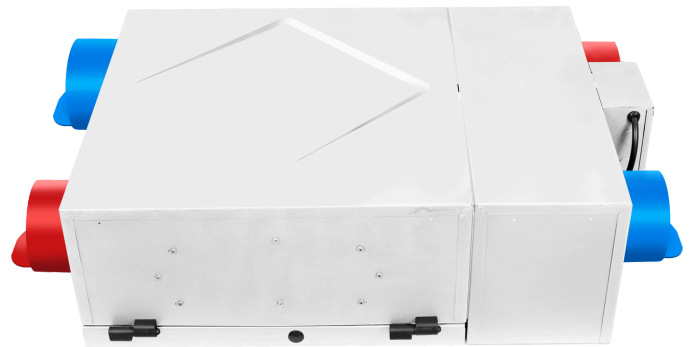

## PACKAGING INSPECTION

Open the box and check to make sure all the parts and accessories are present and in good condition. If you find any parts missing or any shipping damage please contact

## CONTENTS

### Parts List

- RERV-AB150ECM .....1
- RHRV-AB150PECM

### Wiring Diagram

- Control Board and Switches .....2
- Furnace / Fan-Coil / Heat Pump .....3
- Interlock
  - Standard Furnace Interlock Wiring
  - Alternate Furnace Interlock Wiring

### HRV and ERV Typical Installations

- Fully Ducted System .....4
- Furnace Return Air-duct connection
- Semi Ducted System
- Horizontal Vertical installation .....5
- Single Vent & Access Door installation .....6
- Drain Connection .....6

### Air Flow Balancing

- Balancing Procedure .....7
- Pitot tube Air flow Balancing .....7

### Maintenance

- Regular Maintenance .....8
- Annual Maintenance .....9

**Troubleshooting** ..... 9-10

**Climate Zone** ..... 10

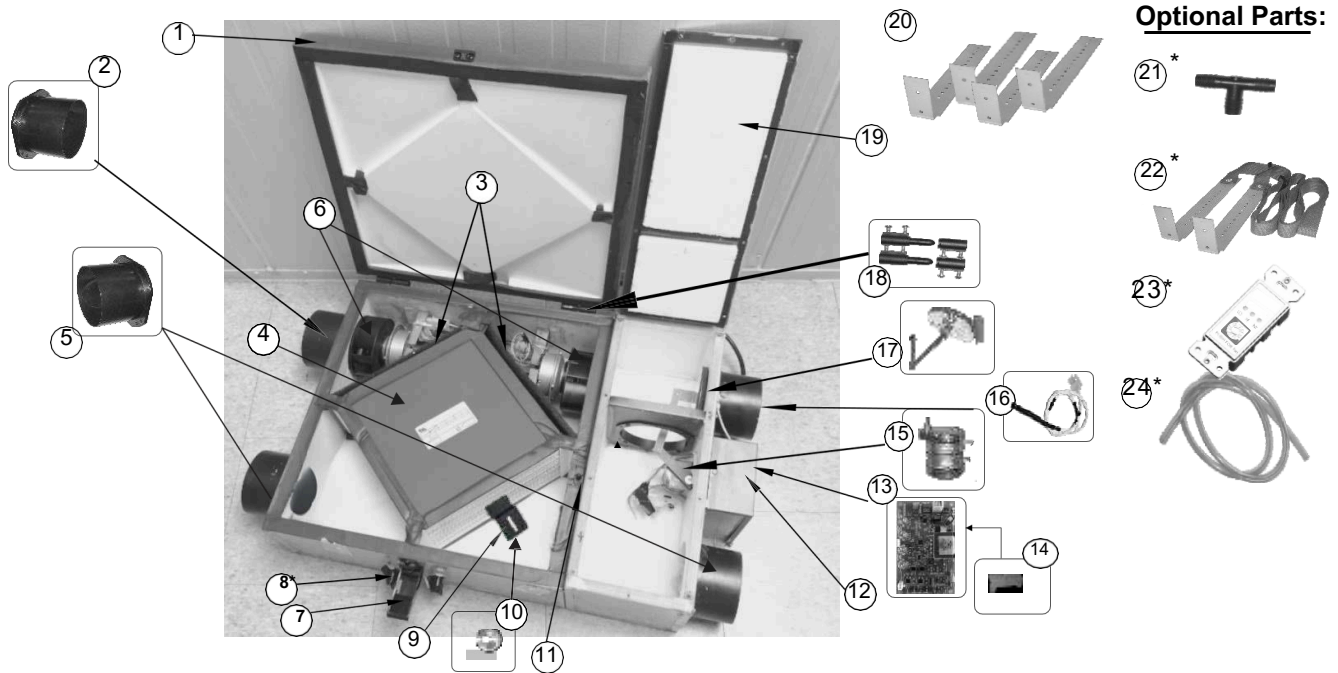

**Optional Parts:**

Reference	Description	Part No.	EPSAX-150
			QTY
1	HRV/ERV -lid, Pan Assembly	9315	1
2	Polypropylene collar 5' Dia.	014043C	2
3	Filter 7" x 12" (MERV -4 )	9358	2
4	Enthalpy Core	9314ECM	1
5	5" Polypropylene Backdraft Damper	14043	2
6	Motor -Exhaust/Supply(ECM)	13085	2
7	Adjustable Door Latch	9319	1
8	Drain Spout Assembly	9320	2
9	Core Locking Bracket	9321	1
10	Nut	14016	1
11	Safety Switch	9322	1
12	Electrical Box Cover	9323	1
13	Main Control Board (ECM)	9361-ECM (DIP) B	1
14	Main Control Board Bracket	9355	2
15	Defrost Motor	9325	1
16	Temperature Sensor	9326	1
17	Defrost Damper Assembly	9327	1
18	Door Hinges	9328	1 Set
19	Extension Box Cover	9329	1
20	Mounting Brackets	11135	4
21*	"T" Connector	9330	1
22*	Webbing/Brackets/Ladder Locks	9332	2 Sets
23*	Electronic Timer Switch (TC100)	9349	1
24*	Drain Pipe	9331	1

# Wiring Diagram : Superior ECM with & without DIP Switch

Optional Accessories (Not Supplied)

- a) Timer Switch (TC100-5V) (old/new)
- b) Wall Switch
- c) Dehumidistat
- d) Time Delay Switch (TC100-120 & TC100-120P)
- e) Master On/Off Switch for HRV/ERV
- f) Light
- g) Intermittent Switch (old/new) (IC100-5V)

**Note:**

Up to 4 Timer Switches (TC100-5V) and one intermittent switch (IC 100-5V) can be connected to control board of HRV/ERV by using three 24 AWG (min.) standard Copper wires as shown. Maximum total wire length 75ft. (see option 2)

**Option 2:**



(Also available without OFF mode)

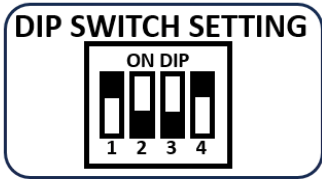
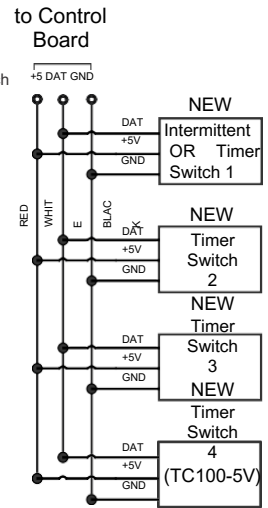
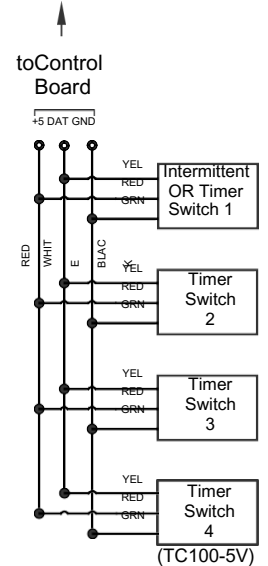

**Light / Switch Option**

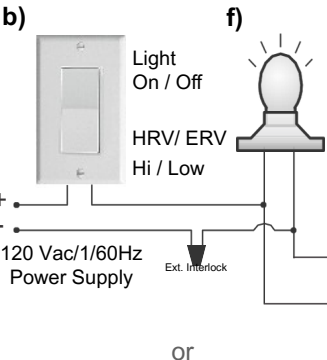

4-Speed Controller for Manual Balancing and Air Flow Adjustment (Turn the Knob clockwise to increase speed)

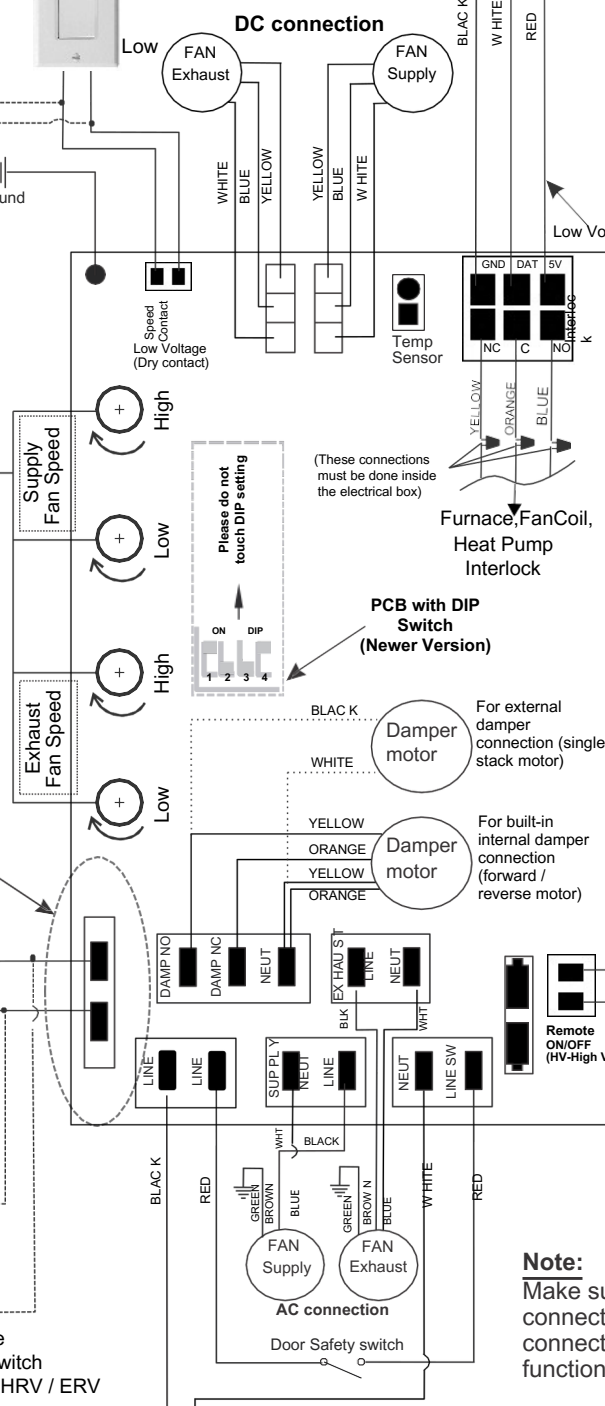

**Note:**

Make sure, the Line must be connected to Line and Neutral connected to Neutral. Unit will not function if not connected correctly.

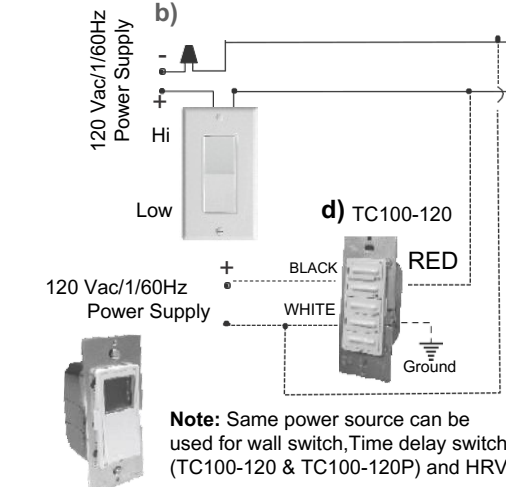

**Note:** Same power source can be used for wall switch, Time delay switch (TC100-120 & TC100-120P) and HRV / ERV

TC100-120P

120 VAC/1/60Hz Power Supply

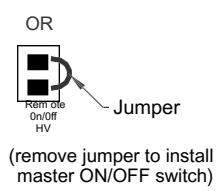

(remove jumper to install master ON/OFF switch)



## Typical Installations for House

### Fully Ducted System

This is a stand-alone HRV/ERV system which is not connected to a force air system. Stale air is drawn from key areas of the home (bathroom, kitchen) while fresh air is supplied to main living areas.

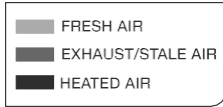

Wall Cap Exhaust/Intake WCE-5, WCI-5 shown  
 \*Re - Circulation Efficiency  
 If distance "X" is 5ft - 99.7%  
 "X" is 3ft - 96.5%

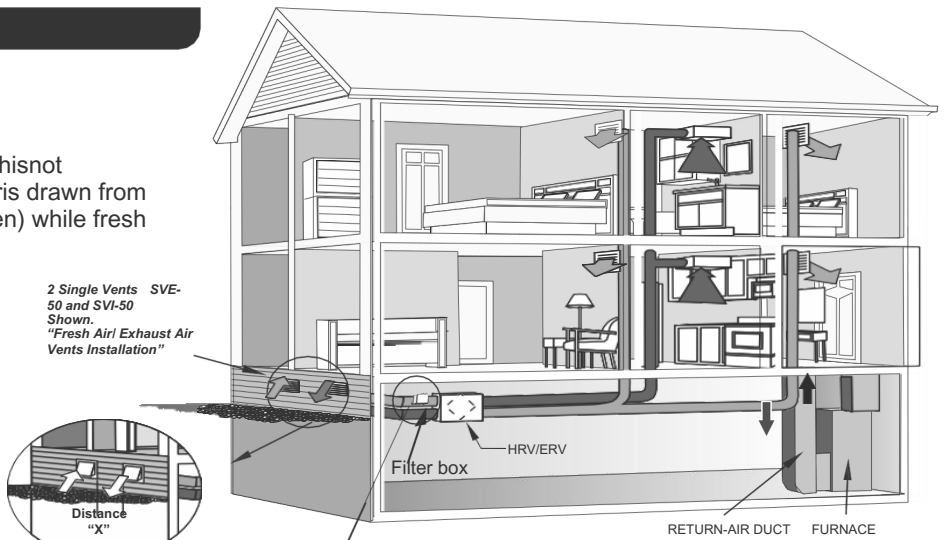

### Furnace Return Air-duct Connection

DVS100  
 Double Vent with hood shown "Fresh Air/Exhaust Air Vent installation"

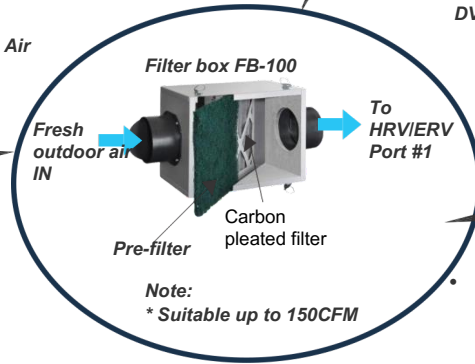
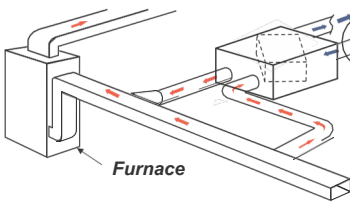

Note:  
 \* Suitable up to 150CFM

### Semi Ducted System

Double Vent with Extruded Aluminum Grille DVG200 shown "Fresh Air/Exhaust Air Vent installation"

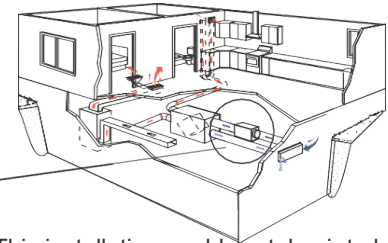

This installation enables stale air to be drawn from the poorest air quality areas of the home (washrooms & kitchen)

**Note:**

- It is recommended that the furnace blower run continuously or HRV/ERV operation be interlocked with the furnace blower to evenly distribute the fresh air throughout the house.
- A backdraft damper is required in the exhaust air duct to prevent outdoor air from entering the unit when the Furnace / Airhandler is running and the unit is in Standby, OFF or in Recirculation.

## Installation Options for High-Rise Condominium

### Fully Ducted System

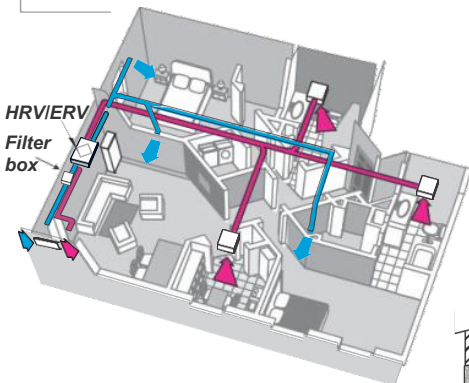

Balancing Box (recommended air filter for auto balancing unit to prevent dust build-up on air flow sensors)

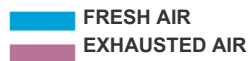

### With Fan-Coil System

Fresh air from outside should be installed on Fan-coil supply side (HRV/ERV station #2) and HRV/ERV should be interlocked with Fan-coil unit.

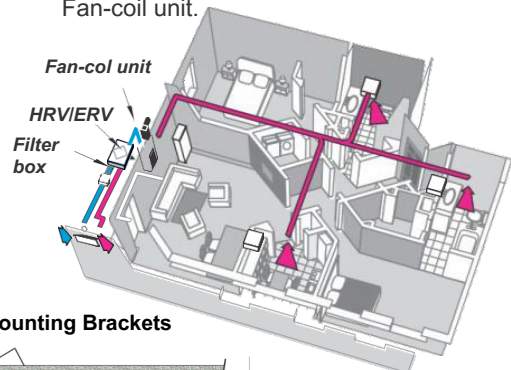

### Mounting Brackets

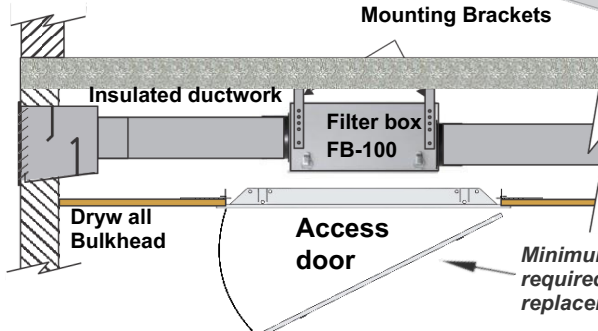

Minimum 24" x 12" access door required for filter cleaning & replacement

**Note:**

- All Exhaust Vents must be installed min. 5 ft away from sidewalls.

**Note:** All HRV / ERV must be balanced in the field.

## HORIZONTAL

- 32" clearance is recommended for cleaning of the core/servicing the unit.  
(use appropriate access door size)
- Dampers are installed for horizontal installation. For vertical installation both dampers have to be turned so they can open properly and close when there is any backdraft.
- **Make sure no screw will interfere the function of the backdraft damper flaps while installing the duct work to the HRV/ERV.**

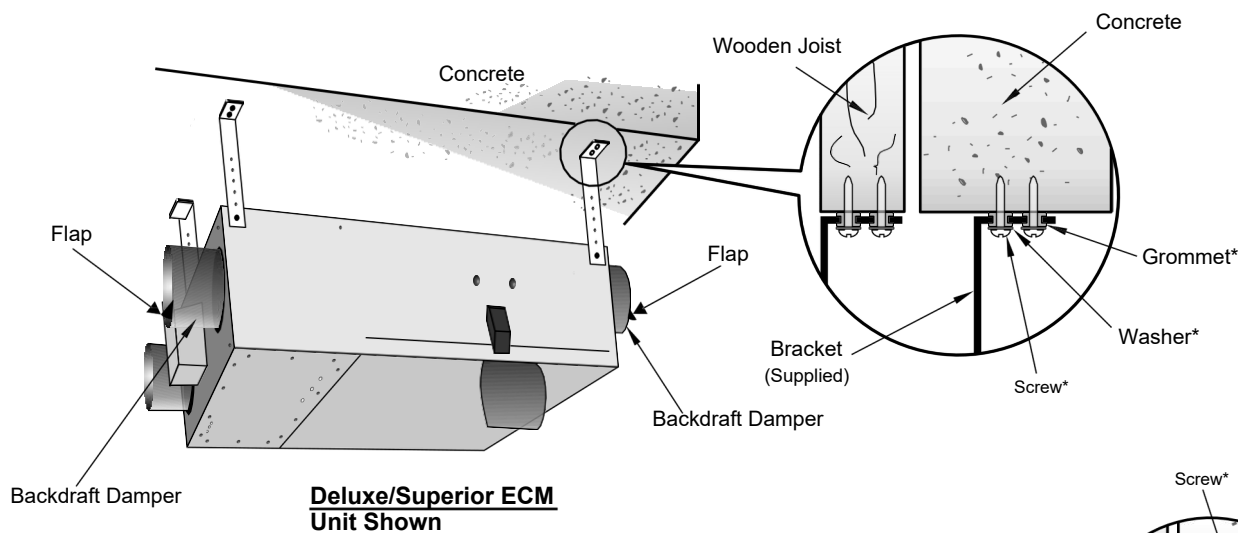

## VERTICAL

**STRAPPING SYSTEM:**  
(optional)  
Allows one person installation for vertical and horizontal installation.

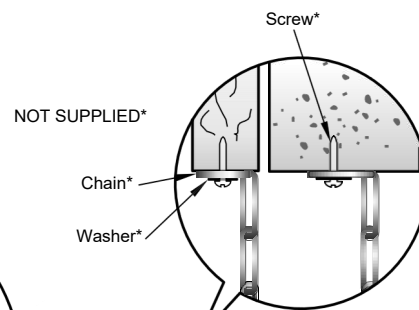
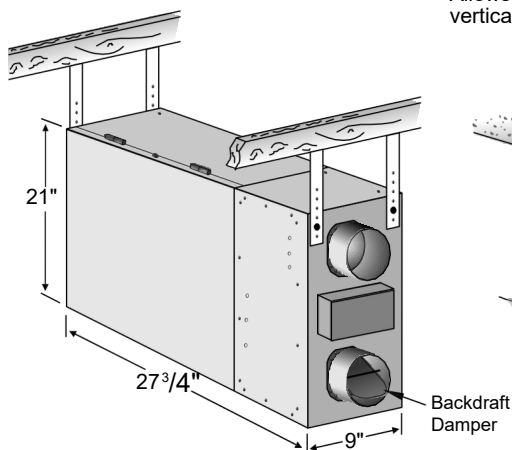

**CHAIN MOUNTING SYSTEM:** (optional)  
Available for both horizontal & vertical installation.

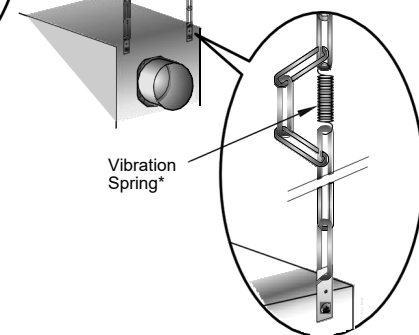

**Note:**

- After installation make sure the HRV/ERV is properly leveled. If not levelled correctly, then defrost will not perform effectively and/or unit may frost in winter.
- Also make sure you have proper defrost on wall - controller according to HRV / ERV model no. / core type.

## Typical Installations of Single Vents & Access door

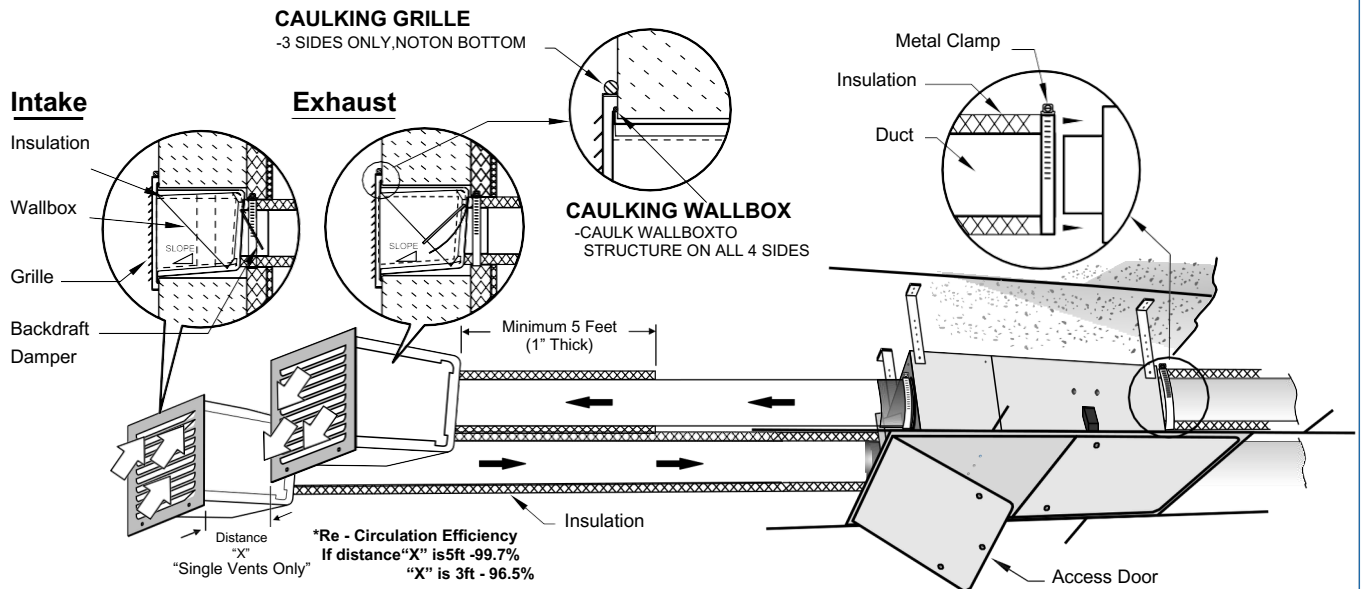

**Note:**

Fresh air intake and supply duct must be totally insulated. Exhaust duct must be 5 feet insulated from the wall. In colder climate, it is recommended to insulate all exhaust and supply ducts.

-Check your building code for Insulation requirement

-Use appropriate access door size and install on proper location for easy access to all HRV/ERV components for routine check and maintenance of the unit.  
For more info visit : <https://auroris.org/accessories/>

## Drain Connection

During defrost cycle the HRV unit may produce some condensation and the water should flow into a nearby drain.

The HRV cabinet has pre-punched holes (two on side and one on the door) for the drain, in order to keep the drain pan intact, **hand tighten** the plastic drain spout to the unit using the gasket and nuts.

### For Vertical installation

Cut two sections of 1/2" drain pipe and connect the other ends to the drain spout then connect to "T" connector. Connect a drain line and create a **P-trap** to prevent the unit from unpleasant odours from drain source. Tape or fasten base to avoid any bends.

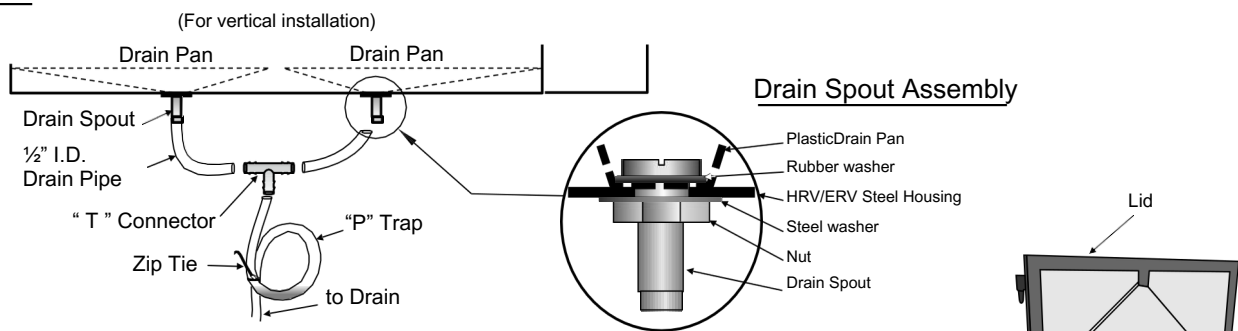

**Note:**

**For Horizontal installation,** connect only 1 drain spout assembly on lid / door. cut one 1/2" drain pipe and connect one end to the drain spout and the other end to the drain line. Don't forget to create a P-trap as shown above.

Use this drain for horizontal installation

**CAUTION**

The HRV and all condensate lines must be installed in a space where the temperature is maintained above the freezing point or freeze protection must be provided.

## For units without built-in true Automatic Electronic Air-balancing and for cross verification only

### Balancing Procedure

It is required to have balanced air flows in an HRV/ERV. The volume of air brought in from the outside must equal the volume of air exhausted by the unit while running at normal speed. If the air flows are not properly balanced, then:

- The HRV/ERV may not function at its maximum efficiency
- A negative or positive air pressure may occur in the house or condo
- The unit may not defrost properly

#### Prior to balancing, ensure that:

1. All the HRV/ERV's components are in place and functioning properly.
2. All sealing of the ductwork system has been completed.
3. Set the unit to normal speed.
4. Air flows in branch to specific areas of the house should be adjusted first prior to balancing the unit.
5. After taking reading of both the stale air to the HRV/ERV duct and fresh air to the house duct, the duct with the lower CFM reading should be left alone while the duct with the higher airflow should be slower down to match the lower reading by adjusting dial/speed controller on control board (see board layout on page-4). Return unit to appropriate fan speed for normal operation.

### Pitot Tube Airflow Balancing

The following is a method of field balancing an HRV/ERV using a Pitot tube advantageous in situations when flow stations are not installed in the ductwork. Procedure should be performed with the HRV/ERV on normal speed.

The first step is to operate all mechanical systems on most desire speed, which have an influence on the ventilation system, i.e. the forced air furnace or air handler if applicable. This will provide the maximum pressure that the HRV/ERV will need to overcome, and allow for a more accurate balancing of the unit.

Drill a small hole in the duct (about 3/16"), three feet downstream of any elbows or bends, and one foot upstream of any elbows or bends. These are recommended distances but the actual installation may limit the amount of straight duct.

The Pitot tube should be connected to a magnehelic gauge capable of reading from 0 to 0.25 in. (0-62 Pa) or other digital airflow meter. The tube coming out of the top of the pitot is connected to the high pressure side of the gauge/meter and the tube coming out of the side of the pitot is connected to the low pressure or reference side of the gauge/meter.

Insert the pitot tube into the duct; pointing the tip into the airflow. For general balancing it is sufficient to move the pitot tube around in the duct and take an average or typical reading. Repeat this procedure in the other duct. Determine which duct has the highest airflow (highest reading on the gauge). Then slower down that motor speed by adjusting dial/speed controller on control board to match the lower reading from the other duct. The flows should now be balanced. Actual airflow can be determined from the gauge/metre reading. The value read on the gauge is called the velocity pressure and on the flow meter is called air velocity (FPM). The Pitot tube comes with a chart that will give the air flow velocity based on the velocity pressure indicated by the gauge. This velocity will be in either feet per minute or metres per second. To determine the actual airflow, the velocity is multiplied by the cross sectional area of the duct being measured.

#### Pitot tube and gauge

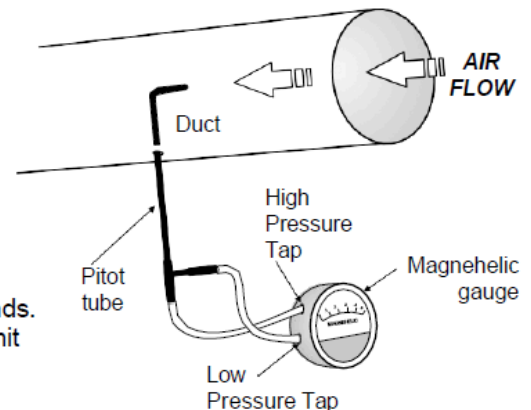

#### NOTE:

Place the magnehelic gauge on a level surface and adjust it to zero.

**Note:(Option #2)**

- \*For balancing, extension box cover plate is provided with 3 holes on supply side and 3 holes on exhaust side.
- \*Do not use pitot tube to open holes in the insulation as it may block/damage the pitot tube.
- \*Take 3 readings on each hole and average all 9 readings for supply and same for exhaust.
- \*After finish balancing, plug all six holes with plastic plugs provided with the unit.

DUCT DIAM.	CROSS SECTION AREA
5"	0.136 sq. ft.
6"	0.196 sq. ft.

$\Delta P''$		CFM
$\varnothing 5$	$\varnothing 6$	
0.010	0.004	50
0.012	0.006	60
0.016	0.008	70
0.022	0.010	80
0.027	0.013	90
0.034	0.016	100
0.041	0.020	110
0.048	0.023	120
0.057	0.027	130

$\Delta P''$ = Velocity Pressure in inch

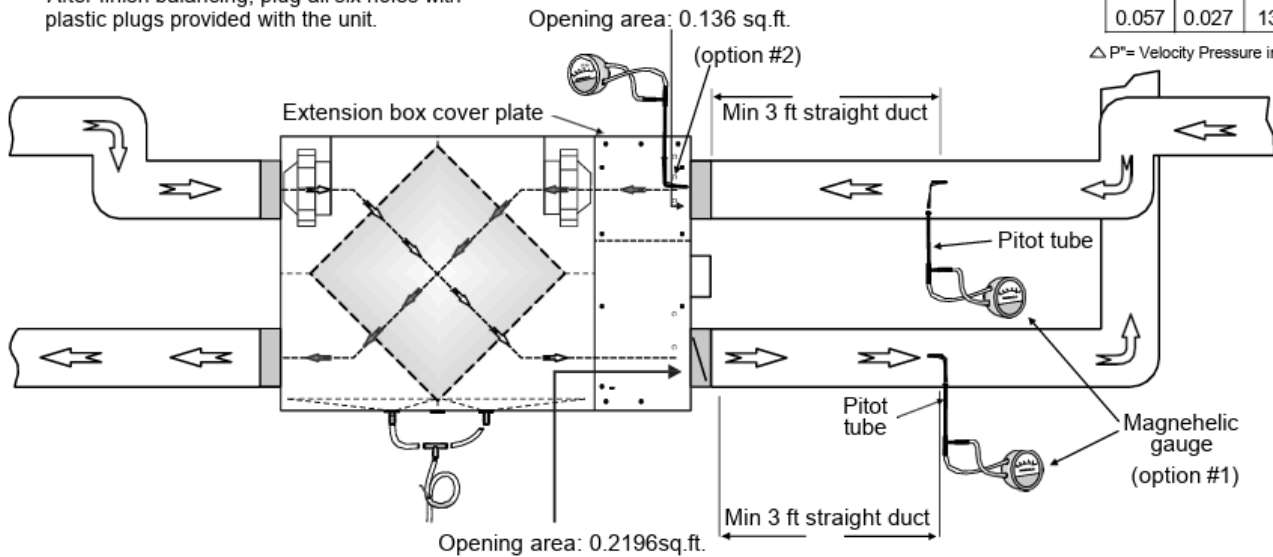

**Note:** To take more accurate readings, use option #1(if possible).

$$CFM = \text{Opening} / \text{Cross-sectional Area(sq.ft.)} \times \text{velocity(FPM)}$$

The accuracy of the flow reading will be affected by how close to any elbows or bends the readings are taken. Accuracy can be increased by taking an average of multiple readings as outlined in the literature with the Pitot tube.

## Maintenance

### Regular Maintenance

1. Turn the unit off and disconnect the power supply.
2. Unlatch the door and lift the door panel towards you, hold it firmly and slide it to the left.
3. Clean the inside of the *door* and *drain pan* with a damp cloth to remove dirt and debris that may be present.
4. Clean the *filters*: (twice a year)
  - Remove the filters.
  - Vacuum to remove most of the dust.
  - Wash with a mixture of warm water and mild soap. Rinse thoroughly and shake filters to remove water and let dry.
5. Oil/grease defrost damper levers and hinges.
6. Check the exterior fresh air supply hood:
  - Make sure there are no leaves, twigs, grass, ice or snow that could be drawn into the vent.

**Partial blocking of this air vent could cause the unit to malfunction.**
7. Reassemble the components, Filters and Door (The door is secured when you hear a click.)
8. Reconnect the power and turn on the unit.

## Annual Maintenance

Repeat steps 1 to 5 from the previous section and continue with the following steps:

**1. Clean the HRV and ERV core:**

- Remove filters, Loosen the core locking bracket, Remove the core, carefully grip ends of core and pull evenly outward
- **HRV Core** > remove dust using vacuum cleaner or rinse with cold water
  - > Soak and rinse the HRV core in warm soapy water
- **ERV Core** > remove dust using vacuum cleaner

**2. Motors - Maintenance Free, permanently lubricated**

**3. Drain Tube and Drain Pipe** - Inspect drain tube, drain pipe and "P" trap for blockage, mold or kinks. Flush with warm soapy water and replace if worn, bent or unable to clean.

**4. Clean Duct Work if Required** - Wipe and vacuum the duct once every year. The duct work running to and from HRV/ERV may accumulate dirt. You may wish to contact a heating / ventilation company to do this.

**5. Cleaning the Fans** - Fans may accumulate dirt causing an imbalance and/or excessive vibration on the HRV/ERV. A reduction in the air flow may also occur. In new construction this may result within the first year due to heavy dust and may occur periodically after that over time depending on the outdoor conditions.

- open the service door
- remove the core
- disconnect the fan motor wires
- remove the screws securing fan assembly
- pull the fan assembly out of unit
- check for any accumulation on the blades
- clean with a small brush if necessary:
  - scrub individual fan blades until clean
  - vacuum and wipe
- put the components back in place
- reconnect the power supply and turn the unit back on.

**6. Cleaning airflow Sensors** - Dirt/Lint may accumulate on the air-flow sensors located on supply (#1) & exhaust (#2) sides and may cause "E3" or "E5" error on wall display (review page-14). To clean sensors,

- Mark both supply and exhaust sensors position & location on the diffuser.
- Remove screws & pull out both sensors gently.
- Clean the circuit board/sensors with a lintfree cloth (Take extra care while cleaning)
- Replace both sensors on their original position & location
- Tight screws

**⚠ ATTENTION ⚠**

- Do not use cleaning solution for the HRV/ERV core
- Do not use pressure washer on the HRV/ERV core
- Do not place the HRV/ERV core in dishwasher
- Do not use bleach or chlorine

**⚠ WARNING ⚠**

**Electrical shock hazard. Can cause injury or death. Before attempting to perform any service or maintenance, always disconnect the unit from its power source.**

## Troubleshooting

\*Only for Deluxe ECM series

PROBLEMS	POSSIBLE CAUSES	SOLUTION
1. Air flow is low	<ul style="list-style-type: none"> <li>- HRV/ERV airflow improperly balanced (<i>for units without built-in Automatic Electronic Air-balancing</i>)</li> <li>- filter clogged</li> <li>- core obstructed</li> <li>- exterior fresh air supply blocked</li> <li>- ductwork is restricting</li> <li>- power supply low (Low Voltage)</li> </ul>	<ul style="list-style-type: none"> <li>- have professional balancer or contractor balance the unit</li> <li>- remove and clean filter</li> <li>- remove and clean core</li> <li>- remove and clean the blockage</li> <li>- inspect duct installation</li> <li>- switch off the unit immediately and call the electrician to check the voltage</li> </ul>
2. Senses cold air from Supply	<ul style="list-style-type: none"> <li>- Exhaust hood outside the house is blocked</li> <li>- HRV/ERV airflow improperly balanced (<i>for units without built-in Automatic Electronic Air-balancing</i>)</li> <li>- outdoor temperature is extremely cold</li> </ul>	<ul style="list-style-type: none"> <li>- remove the blockage and clean the hood</li> <li>- have professional balancer or contractor balance the unit</li> <li>- placement of furniture or closed doors is restricting the movement of air in the home</li> <li>- install a duct heater</li> </ul>
3. Water in the bottom of HRV	<ul style="list-style-type: none"> <li>- drain pans, drain tube, drain pipe and "P" trap are clogged</li> </ul>	<ul style="list-style-type: none"> <li>- check for blockage and for kinks in line</li> <li>- check connections</li> <li>- make sure water drains properly</li> </ul>

PROBLEMS	POSSIBLE CAUSES	SOLUTION
<p>4. "Wall Mount Unit" showing error Codes:</p> <ul style="list-style-type: none"> <li>- Error Code "E1"</li> <li>- Error Code "E2"</li> <li>- Error Code "E3"</li> <li>- Error Code "E4"</li> <li>- Error Code "E5"</li> </ul> <p>Note:- E3 &amp; E5 will not be displayed on non-balancing Deluxe, Superior, and Maxum units.</p>	<ul style="list-style-type: none"> <li>- loss of communication with the Control Board. HRV/ERV switched to OFF mode automatically.</li> <li>- defrosting Temperature Sensor Failure. Blinks with the current operational display. HRV/ERV does not perform defrost cycles.</li> <li>- airflow Sensor Failure. Blinks with the current operational display. HRV runs at fixed default Low and High fans speeds.</li> <li>- Humidity Sensor Failure. Blinks with the current operational display. HRV does not run in High Humidity mode.</li> <li>- Kinked duct</li> <li>- Heavy dust built on air-flow sensors</li> <li>- Blinks with the current operational display. HRV/ ERV stops fans, closes damper &amp; opens furnace/fan-coil/ heat pump interlock relay.</li> <li>- Fans Failure.</li> </ul>	<ul style="list-style-type: none"> <li>- check wall control connections</li> <li>- clean temperature sensor, if it still shows "E2" error replace temperature sensor</li> <li>- clean dust and reinstall, if it still shows "E3" error replace the air flow sensors.(supply / exhaust pair)</li> <li>- replace humidity sensor</li> <li>- use straight metal duct work as possible</li> <li>- clean both air-flow sensors</li> <li>- check all ducts for blockage</li> <li>- make sure all backdraft dampers on the unit are working fine and no screws are interfering the backdraft damper function</li> <li>- Replace intake fan/exhaust fan</li> </ul>
<p>5. Timer switch 20/40/60 minute light doesn't stay on</p>	<ul style="list-style-type: none"> <li>- loose connection</li> <li>- the switch may be defective</li> </ul>	<ul style="list-style-type: none"> <li>- check connection</li> <li>- replace the timer switch</li> </ul>
<p>6. Defrost Mode does not work</p>	<ul style="list-style-type: none"> <li>- fresh air duct maybe frozen</li> <li>- HRV/ERV airflow improperly balanced (<i>for units without built-in Automatic Electronic Air-balancing</i>)</li> <li>- defrost damper motor maybe defective</li> <li>- Temp. sensor maybe defective</li> <li>- improper defrost cycle</li> </ul>	<ul style="list-style-type: none"> <li>- check and remove the ice</li> <li>- have professional balancer or contractor balance the unit</li> <li>- replace the defrost motor</li> <li>- replace the temp. sensor</li> <li>- check defrost cycle on wall - control and reprogram</li> </ul>
<p>7. All 3 LEDs of timer switch blinks</p>	<ul style="list-style-type: none"> <li>- Control board reports error</li> <li>- lost communication with main control board</li> </ul>	<ul style="list-style-type: none"> <li>- refer to problem 4.</li> <li>- check all wire connections on timer switch and main control board</li> </ul>
<p>8. No display on wall - control</p>	<ul style="list-style-type: none"> <li>- wires are shot</li> <li>- loose connection</li> </ul>	<ul style="list-style-type: none"> <li>- check continuity and replace the wires</li> <li>- check connections on main controller and wall controller</li> <li>- replace wall - controller</li> </ul>

## Select HRV/ERV for your Climate Zone

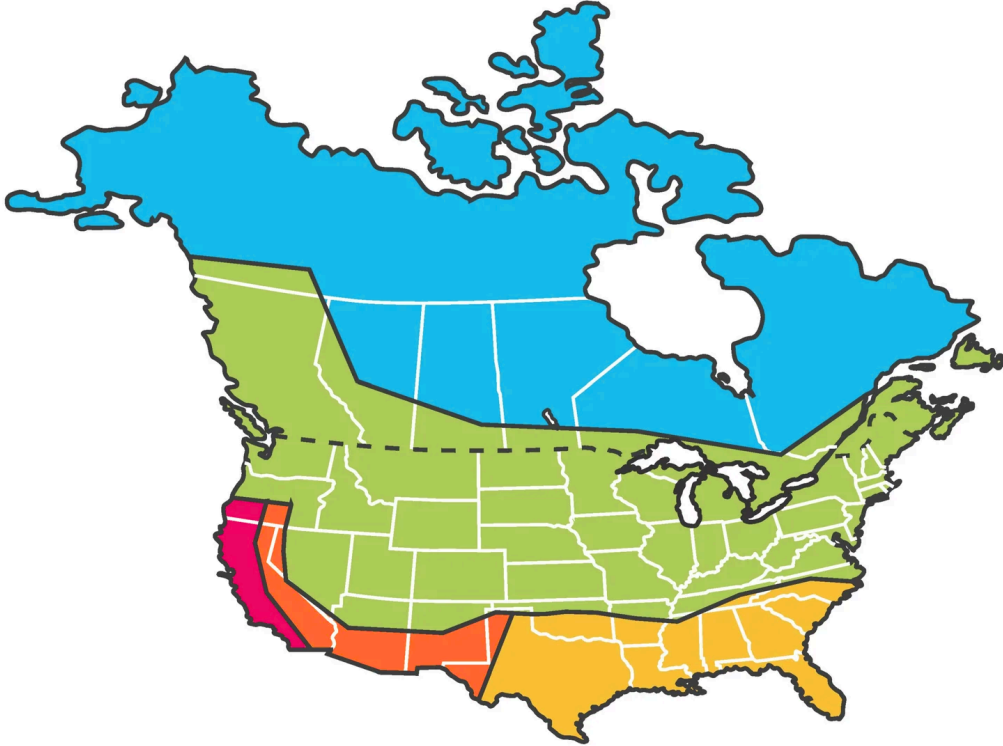

<b>HRV</b>		<b>HRV, ERV</b> (optional)	
	Severe Conditions		Pacific Conditions
	Moderate Conditions	<b>ERV</b>	
	Dry Climate		High Humidity

*U.S. Department of Energy climate zones map*

*HRVs are recommended for colder climates.*

*ERVs are designed for warm-humid climates with long cooling seasons.*



888.863.1562 | [info@auroris.org](mailto:info@auroris.org) | [www.auroris.org](http://www.auroris.org)